

# CAD Tools For Very High Speed IC Design

*Jeff Yen, Senior Design Engineer*



# Very High Speed Circuit Types

- **Broadband, analog, & mixed signal**
  - **Optical network physical layer components**
    - ◆ **Optical – electronic interface**
      - » Transimpedance amplifiers
      - » Limiting amplifiers, AGC amplifiers
      - » Modulator & laser drivers
    - ◆ **Serializers / deserializers (high-speed – low-speed interface)**
      - » Mux / demux
      - » Frequency dividers
      - » Clock multiplier and clock recovery PLLs
      - » High-speed logic gates



# Very High Speed Circuit Types (con't.)

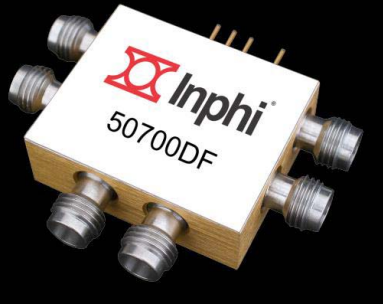

- Discrete high-speed logic components
  - Ultra high performance logic gates

- Narrowband analog circuits

- Millimeter-wave components: oscillators, amplifiers, mixers, nonlinear filters



- Test & measurement systems
  - Can incorporate any of the above

# Circuit Design Methods

- **Several types of analysis necessary**
  - Time domain analysis for irregular & regular signals
  - Frequency domain analysis
    - ◆ Frequency response
    - ◆ Return loss
    - ◆ Noise performance
  - Mixed-mode analysis
    - ◆ Simulation of mixed behavioral + physical circuits
- **Very high frequency effects must be included**
  - Familiar ground for narrowband circuit design
  - Transmission lines, passive structures must be modeled
  - Sophisticated device & passive element modeling required

# Cadence Custom IC Design Suite

- **SPECTRE simulator engine**
  - SPICE-like DC & time domain simulations
  - Sophisticated frequency domain simulations
  - Advanced BSIM3, VBIC models for CMOS, bipolar, BiCMOS design
- **Versatile design automation**
  - Composer schematic capture
  - Virtuoso layout editor
  - Assura design verification
    - ◆ Also supports Mentor Graphics' Calibre
- **Standards-based mixed-mode simulation**
  - Supports Verilog-HDL, Verilog-A, Verilog-AMS, VHDL behavioral models
- **Tool of choice for lower speed design flows moving to higher speeds**



# Agilent EEsof ADS Software

- **True electromagnetics-based frequency domain simulation**
  - Unrivalled capabilities for incorporation of distributed circuit effects
  - Interfaces with finite element electromagnetic system model
  - Superior custom device modeling capabilities
  - Mature nucleus “software of choice” for frequency domain simulation
- **Limited schematic, layout, design verification, mixed-mode simulation capabilities**
- **Tool of choice for narrowband design flows moving to broadband, mixed signal**

# Broadband Amplifier Design Example

## Agilent EEsof ADS

- **Demonstrate advanced capabilities suited to very high speed circuit design**
  - Broadband amp simulation example
  - VBIC bipolar transistor model + Inphi proprietary design model
  - Physically modeled transmission line
    - ◆ Highly accurate analytical frequency domain (convolved into time domain) representation
    - ◆ Readily verified over broad frequency range against measured S-parameters of IC structures
  - Sophisticated stimulus and results display features



# Schematic Entry & Testbench Setup

- **Amplifier circuits**
  - Cherry-Hooper\* broadband amp with CML amp load
  - Comparison of results with and without transmission line
- **Signal source & device model**
  - Input signal from LFSR (linear feedback shift register) generating pseudorandom binary data sequence
    - ◆ Broadband spectrum input signal
  - Inphi proprietary model derived from device measurement, model extraction with ICCAP, proprietary enhancements



# Schematic Entry

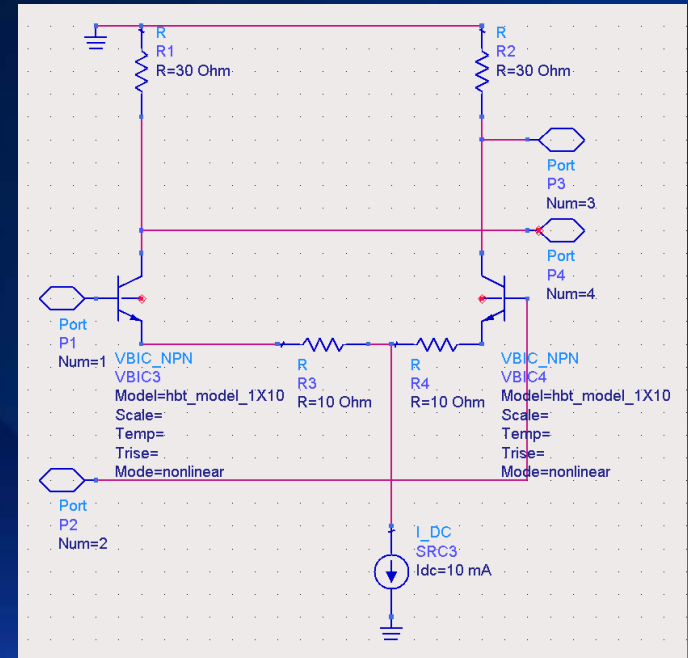
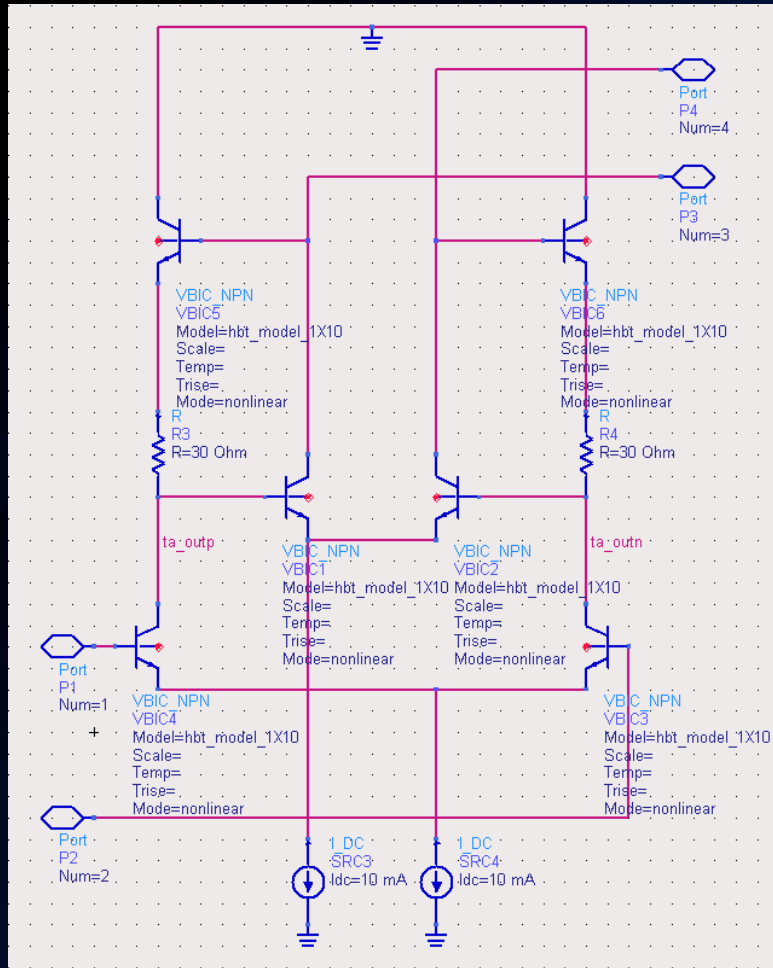

Current mode logic (CML) load stage

Cherry-Hooper amp

# Testbench Setup

Proprietary  
VBIC  
model  
interface

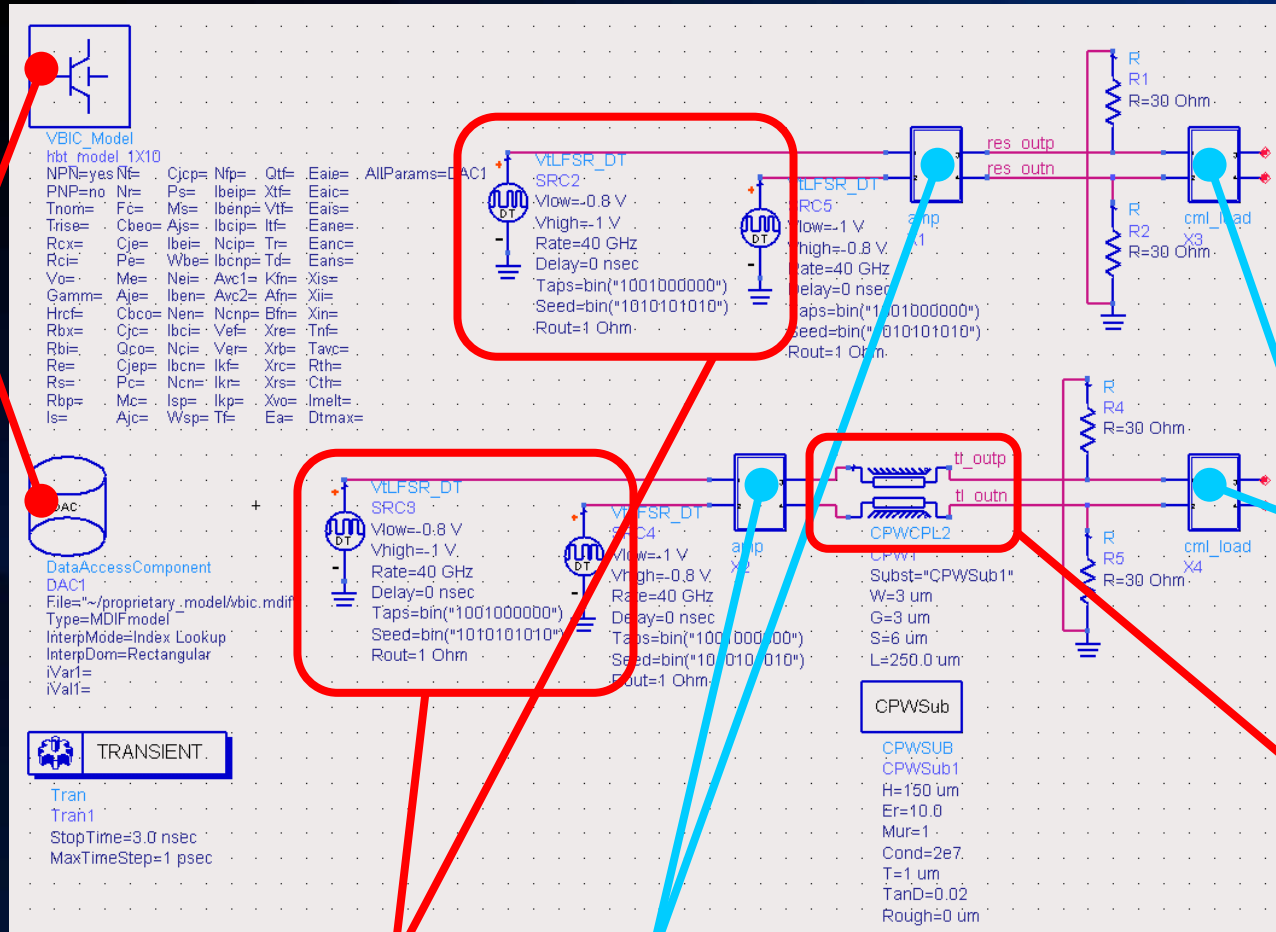

CML loads

Coplanar  
coupled  
lines

LFSR pseudorandom  
bit sequence generators

Cherry-Hooper  
amps



Think fast.

# Simulations Results

Amp output with resistor output load

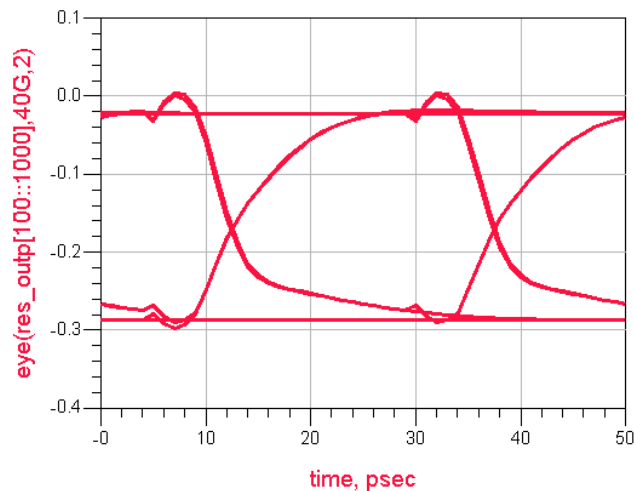

Amp output with terminated transmission line output load

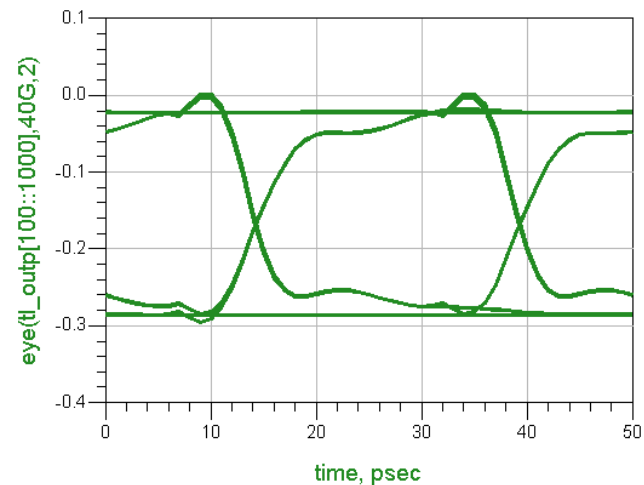

- Transient simulation with implicit frequency domain simulation
- Use “eye” function for displaying data bit eye diagram

# Conclusions

- Both time and frequency domain simulations can be used
- Accurate transmission line models are beneficial
- Sophisticated device models are imperative
- CAD software options available
- Agilent EEsof ADS example
  - Showed benefit of transmission line model
  - Readily implement proprietary device model
  - Mixed time & frequency domain simulation

# Presenter Biographies (con't.)

**Jeff Yen, Senior Design Engineer.** Jeff Yen has an extensive background in high-frequency and mixed-signal circuit design. At Cognet, he developed multi-gigabit CMOS clock and data recovery circuits and limiting amplifiers. At Conexant, he designed a variety of integrated circuits for SiGe/SiBiCMOS and GaAs HBTs for 12.5, 10.7, and 2.5 Gbps systems, including laser and modulator drivers, limiting amplifiers, CDR frequency acquisition circuits, loss of lock/loss of signal detection circuits, and MUX clock multiplier PLL ICs. Mr. Yen holds an M.S. in Electrical and Computer Engineering from the University of California, Santa Barbara and a B.S. in Electrical Engineering from Cornell University.