

40G QPSK and DQPSK Modulation

*By: Application Engineer Lian Zhao, Principal Engineer Hari Shankar,
and Validation Test Engineer Ariel Nachum,
Inphi Corporation*

ABSTRACT

This paper discuss the theory behind differential phase shift keying (DPSK) and differential quadrature phase shift keying (DQPSK) modulation formats and explains in detail how to implement a DQPSK experimental set-up, using Inphi's 2514DZ differential Mach-Zender (MZ) driver.

1 INTRODUCTION

The on-going growing demand for greater capacity in optical communication systems, calls for an increase in transmission speed from 10 Gbps to 40 Gbps and beyond, while maintaining signal quality. Optical communication systems have predominantly used some form of on/off keying (OOK) as a modulation format, namely NRZ or RZ modulation. As data rates increase, the inefficiency of these modulation formats from a bandwidth point of view is becoming more apparent. With data rates moving to 40 Gbps and beyond, dispersion in the fiber limits the distance over which the data can be transmitted. Other impairments such as polarization mode dispersion or PMD become significant at 40 Gbps. Thus, inter-city transmission, which requires long-distance transmission of more than several hundred kilometers, has not been possible [1]. Transmission links are rapidly evolving from point-to-point links to interconnected optical networks. This requires the flexibility to pass multiple optical add-drop multiplexer (OADM) nodes along the transmission link. Today, most transmission systems have a 50 GHz WDM channel spacing, which implies a 0.8 bit/s/Hz spectral efficiency for 40 Gbps transmission [2]. For binary formats, duobinary and differential phase shift keying (DPSK) are close to the theoretical limit, which makes it difficult to cascade multiple OADMs along transmission link [6], [7]. The narrower optical spectrum of multi-level formats such as QPSK and differential quad phase shift keying (DQPSK) therefore enables both a high spectral efficiency as well as the possibility to cascade multiple OADMs.

2 THEORY of DQPSK

2.1 Dispersion and Bandwidth Efficient Schemes: NRZ, QPSK and DQPSK

NRZ intensity modulation format is widely used at 10 Gbps right now. The following figures show the effect of dispersion in a single mode fiber for NRZ modulation at 40 Gbps. The dispersion coefficient of the fiber is $D = 17\text{e-}6 \text{ sec/m/m}$.

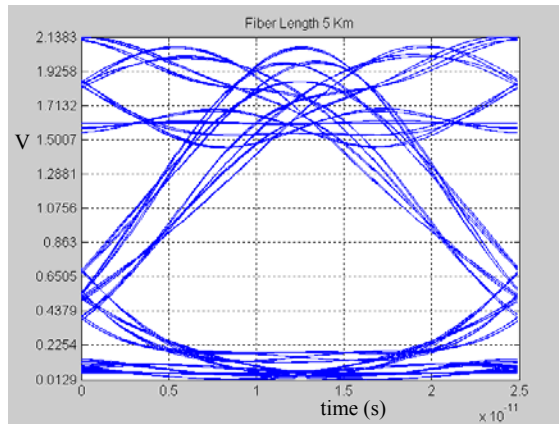

Fig 1a: 40 Gbps Received Eye Over 5 Km Fiber, $D = 17\text{e-}6 \text{ sec/m/m}$

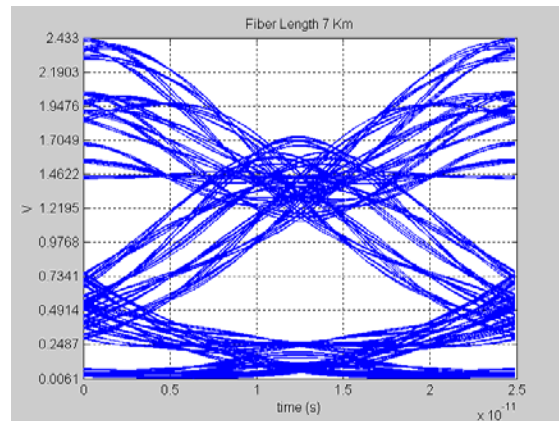

Fig 1b: 40 Gbps Received Eye Over 7 Km Fiber, $D = 17\text{e-}6 \text{ sec/m/m}$

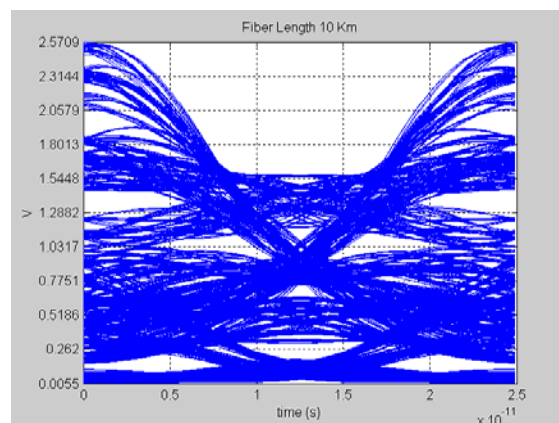

Fig 1c: 40 Gbps Received Eye Over 10 Km Fiber, $D = 17\text{e-}6 \text{ sec/m/m}$

Some of the more bandwidth efficient schemes that have been explored in optical communications are duobinary and QPSK. The theoretical bandwidth required to transmit a signal at a rate of R symbols/sec with no inter symbol interference is $R/2$ Hz (Ref [1]). Duobinary decreases the bandwidth of the transmitted signal to a value less than this limit by introducing some ISI which is unraveled later. However, it still transmits 1 bit per symbol and hence the symbol rate equals the bit rate. QPSK is more efficient because it transmits 2 bits per symbol and hence the symbol rate is half the bit rate and the theoretical bandwidth required is $1/4$ of the bit rate (Fig. 2). Hence, the effects of dispersion are considerably less for this modulation format (Ref. [2], [3], [4]). The drawbacks are the increased SNR required and the increase in the complexity of the system. Differential quadrature phase-shift-keying (DQPSK) format provides a promising alternative as it, like QPSK, transmits 2 bits per symbol and hence the symbol rate is half the bit rate with somewhat reduced complexity of the system. DQPSK is tolerant to chromatic dispersion (CD), polarization-mode dispersion (PMD), and has a high spectral efficiency, and thus can be used in ultra long haul transmission as well. Although the configuration of a DQPSK system is less complex compared with a QPSK system, large size and high power consumption of the optical transceivers still pose challenges to designers.

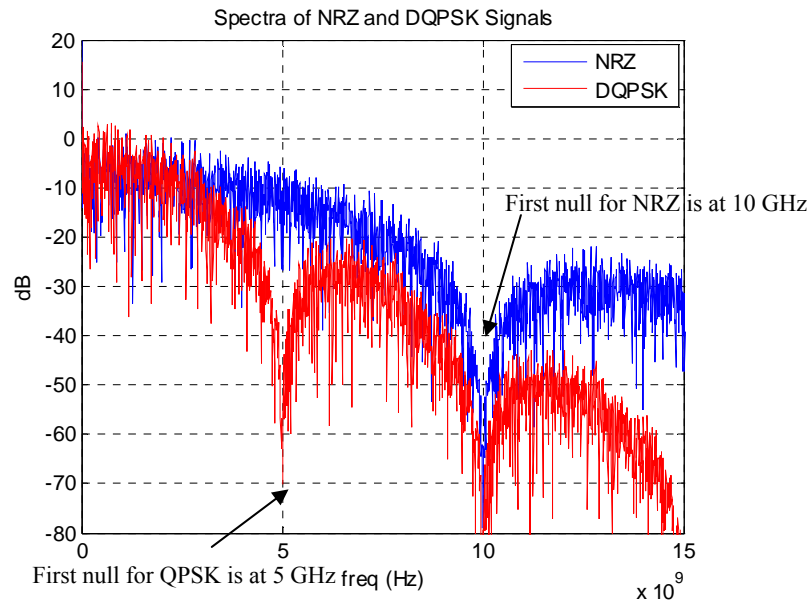

Fig 2: Comparison of spectrum of NRZ and DQPSK at 10 Gbps data rate

2.2 QPSK and DQPSK format comparison

2.2.1 QPSK

In QPSK, the information bits are encoded into the phase of the optical carrier and the amplitude of the signal remains constant. A QPSK signal can be represented as follows

$$x(t) = \cos(2\pi f_c t + \theta(k)), \quad kT \leq t < (k+1)T$$

$$\theta(k) = \begin{cases} \pi/4 & \text{if } (I(k), Q(k)) = (0,0) \\ 3\pi/4 & \text{if } (I(k), Q(k)) = (1,0) \\ 5\pi/4 & \text{if } (I(k), Q(k)) = (1,1) \\ 7\pi/4 & \text{if } (I(k), Q(k)) = (0,1) \end{cases} \quad (1)$$

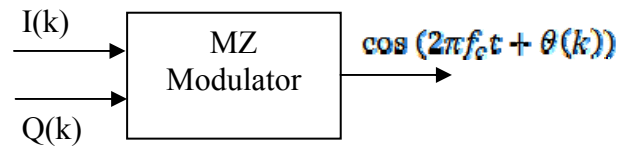

Fig 3a: Optical Modulator

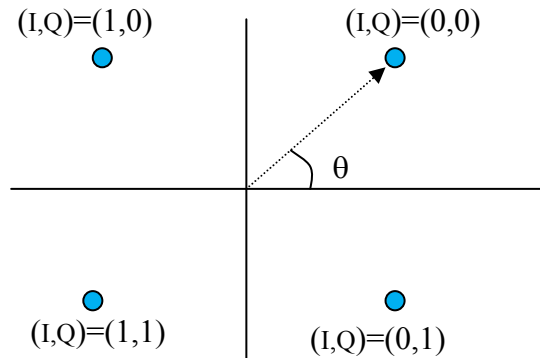

Fig 3b: Mapping of input bits to carrier phase by the modulator

Here, f_c is the carrier frequency, $\theta(k)$ is the phase of the carrier in the time interval $[kT, (k+1)T)$, and $(I(k), Q(k))$ is the k th symbol to be transmitted. The phase varies from one symbol period to the next depending upon the value of the symbol $(I(k), Q(k))$. Let T_b be the bit period and let $T = 2T_b$ be the symbol period. The k^{th} symbol is transmitted in the time interval $[kT, (k+1)T)$. This mapping of the symbol to the phase is done by using a MZ modulator.

An optical QPSK modulator consists of 2 MZ modulators, which further have a $\pi/2$ phase difference between them [Ref. 2].

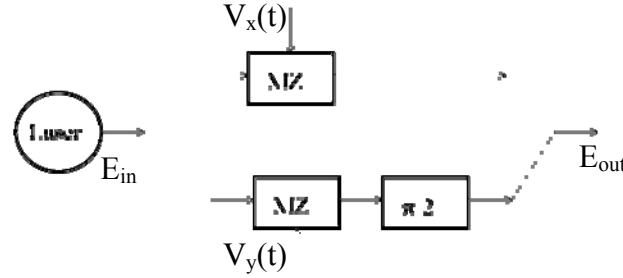

Fig. 4 Optical QPSK modulator with dual MZs

Each of the MZ drivers is biased at its null and the driving voltage levels are set so that the carrier phase on each arm shifts by either $+\pi/2$ or $-\pi/2$. This is twice the voltage level required for NRZ. Assuming that the transfer function of a single MZ is given by $E_{out} = E_{in} \cos(\pi V(t)/V_{\pi})$ (here E_{in} is the input optical signal to the MZ, E_{out} is the output optical signal of the MZ, $V(t)$ is the control signal, and V_{π} is a characteristic of the MZ and determines the amplitude required for the control signal), the transfer function of the QPSK modulator is given by

$$\begin{aligned}
 E_{out} &= E_{in} (\cos(\pi V_x(t)/V_{\pi}) + \cos(\pi V_y(t)/V_{\pi}) e^{j\pi/2}) \\
 &= E_{in} (\cos(\pi V_x(t)/V_{\pi}) + j \cos(\pi V_y(t)/V_{\pi})) \\
 &= E_{in} \sqrt{\cos^2(\pi V_x(t)/V_{\pi}) + \cos^2(\pi V_y(t)/V_{\pi})} e^{j \tan^{-1} \left(\frac{\cos(\pi V_y(t)/V_{\pi})}{\cos(\pi V_x(t)/V_{\pi})} \right)}
 \end{aligned}$$

Now, if $V_x(t)$ and $V_y(t)$ take on one of two values $\{0, V_{\pi}\}$, then the phase shift induced by on the input signal E_{in} is one of four values as shown in Table 1 below

$V_x(t)$	$V_y(t)$	$\cos(\pi V_x(t)/V_{\pi})$	$\cos(\pi V_y(t)/V_{\pi})$	$\tan^{-1} \left(\frac{\cos(\pi V_y(t)/V_{\pi})}{\cos(\pi V_x(t)/V_{\pi})} \right)$
0	0	1	1	$\pi/4$
0	V_{π}	1	-1	$-\pi/4$
V_{π}	0	-1	1	$3\pi/4$
V_{π}	V_{π}	-1	-1	$5\pi/4$

Table 1: Carrier phase shifts in a dual MZ QPSK modulator

Hence, by mapping the input bits to the appropriate voltage level, i.e., input bit 0 to the voltage level 0 and input bit 1 to the voltage level V_{π} , the mapping from bits to phase as shown in Figure 3b is obtained. In practice, control loops are required to control the bias voltages and the voltage required for the $\pi/2$ phase shifter.

By observing the phase, the receiver can determine the symbol that was transmitted. However, a local carrier whose frequency and phase are matched to the frequency and phase of the received signal is required at the receiver.

$$\hat{\theta}(k) = x(t) \cos(2\pi t f_c' + \phi) |_{LFF}$$

$$\hat{\theta}(k) = \cos((f_c - f_c')t + \theta(k) - \phi)$$

Here, $\hat{\theta}(t)$ is the receiver's estimate of the transmitted symbol, f_c' is the frequency of the local carrier at the receiver, and ϕ is the phase of the local carrier. Hence, to get an exact estimate of the transmitted phase, the frequency of the local carrier at the receiver must match that of the received signal, and the phase of the local carrier must equal that of the received signal, i.e., $f_c = f_c'$ and $\phi = 0$. This synchronization is difficult to achieve at optical frequencies. DQPSK, or differential phase shift keying, is one way of avoiding this problem.

2.2.2 DQPSK

In DQPSK, the symbol information is encoded as the phase change from one symbol period to the next rather than as an absolute phase. In this case, the receiver has to detect phase changes and not the absolute value of the phase, which avoids the need for a synchronized local carrier. The transmitted signal can be represented as

$$x(t) = A \cos(2\pi f_c t + \theta(k)), \quad kT \leq t < (k+1)T$$

$$\theta(k) - \theta(k-1) = \begin{cases} \pi & \text{if } (I(k), Q(k)) = 00 \\ 3\pi/2 & \text{if } (I(k), Q(k)) = 10 \\ 0 & \text{if } (I(k), Q(k)) = 11 \\ \pi/2 & \text{if } (I(k), Q(k)) = 01 \end{cases}$$

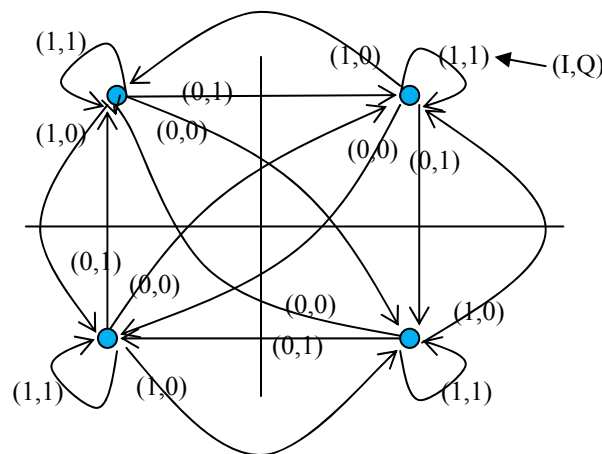

Fig 5: Mapping of input bits to changes in the carrier phase

Compared to QPSK, note that the phase difference from one symbol period to the next is a function of the input symbol and not the absolute value of the phase itself.

2.3 DQPSK transmitter

A DQPSK transmitter includes a DQPSK modulator, two modulator drivers and a precoder. The mapping from the input symbol ($X(k)$, $Y(k)$) to the phase difference of the carrier can be achieved by a precoder which maps the input symbol ($X(k)$, $Y(k)$) to a new symbol or set of bits ($I(k)$, $Q(k)$) as follows

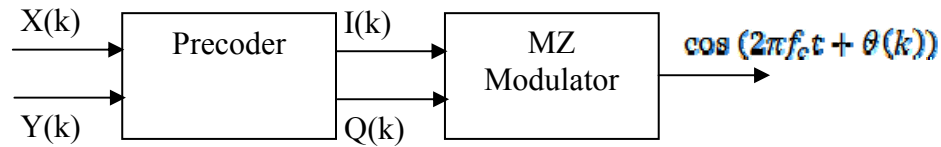

Fig 6: DQPSK Transmitter

The precoder current outputs $I(k)$ and $Q(k)$ are a function of the current inputs $X(k)$ and $Y(k)$ and the previous output $I(k-1)$ and $Q(k-1)$. The mapping from the precoder outputs $I(k)$ and $Q(k)$ to the phase of the carrier is the same as that of the QPSK modulator shown in Figure 3b above. The precoder mapping of the input symbol ($X(k)$, $Y(k)$) to ($I(k)$, $Q(k)$) is given in the table below.

Current Input		Previous Precoder Output		Previous Modulator Phase	Current Precoder Output		Current Modulator Phase	Modulator Phase Change
$X(k)$	$Y(k)$	$I(k-1)$	$Q(k-1)$	$\theta(k-1)$	$I(k)$	$Q(k)$	$\theta(k)$	$\Delta\theta$
0	0	0	0	45	1	1	225	180
0	0	0	1	315	1	0	135	180
0	0	1	0	135	0	1	315	180
0	0	1	1	225	0	0	45	180
0	1	0	0	45	1	0	135	90
0	1	0	1	315	0	0	45	90
0	1	1	0	135	1	1	225	90
0	1	1	1	225	0	1	315	90
1	0	0	0	45	0	1	315	270
1	0	0	1	315	1	1	225	270
1	0	1	0	135	0	0	45	270
1	0	1	1	225	1	0	135	270
1	1	0	0	45	0	0	45	0
1	1	0	1	315	0	1	315	0
1	1	1	0	135	1	0	135	0
1	1	1	1	225	1	1	225	0

Table 2: Mapping of the differential encoder and the modulator

By examining the 1st, 2nd and last columns of Table 2, we see that the mapping from the symbol (X(k), Y(k)) to the change in phase $\Delta\theta$, matches the transitions shown in Figure 4.

2.4 Precoder (or Differential Encoder)

The mapping from (X(k), Y(k)) to (I(k), Q(k)) is given by Table 2. The mappings for each of the bits I(k) and Q(k) are shown in the form of a Karnaugh map in Figure 7 below.

X(k)\Y(k)	00	01	11	10
00	1	1	0	0
01	1	0	0	1
11	0	0	1	1
10	0	1	1	0

X(k)\Y(k)	00	01	11	10
00	1	0	0	1
01	0	0	1	1
11	0	1	1	0
10	1	1	0	0

Fig 7: Karnaugh maps for the precoder

By combining the min terms in different ways, as shown by the orientation of the black and the red ovals in Figure 7, two different implementations of the mapping can be realized. The black oval leads to the first implementation

$$I(k) = \overline{X(k)Y(k)I(k-1)} + \overline{X(k)Y(k)Q(k-1)} \\ + X(k)Y(k)I(k-1) + X(k)\overline{Y(k)Q(k-1)}$$

$$Q(k) = \overline{X(k)Y(k)Q(k-1)} + \overline{X(k)Y(k)Q(k)} \\ + X(k)Y(k)Q(k-1) + X(k)\overline{Y(k)Q(k-1)}$$

The red oval leads to the second implementation

$$I(k) = \overline{X(k)I(k-1)Q(k-1)} + \overline{Y(k)I(k-1)Q(k-1)} \\ + X(k)I(k-1)Q(k-1) + Y(k)I(k-1)\overline{Q(k-1)}$$

$$Q(k) = \overline{Y(k)I(k-1)Q(k-1)} + \overline{X(k)I(k-1)Q(k-1)} \\ + Y(k)I(k-1)Q(k-1) + \overline{X(k)I(k-1)Q(k-1)}$$

A third realization follows from the following equation describing the mapping of the precoder

$X(k)$	$Y(k)$	$I(k)$	$Q(k)$
0	0	$\overline{I(k-1)}$	$\overline{Q(k-1)}$
0	1	$\overline{Q(k-1)}$	$I(k-1)$
1	0	$Q(k-1)$	$\overline{I(k-1)}$
1	1	$I(k-1)$	$Q(k-1)$

Table 3: Truth table for the precoder

This can be realized with muxes as shown below

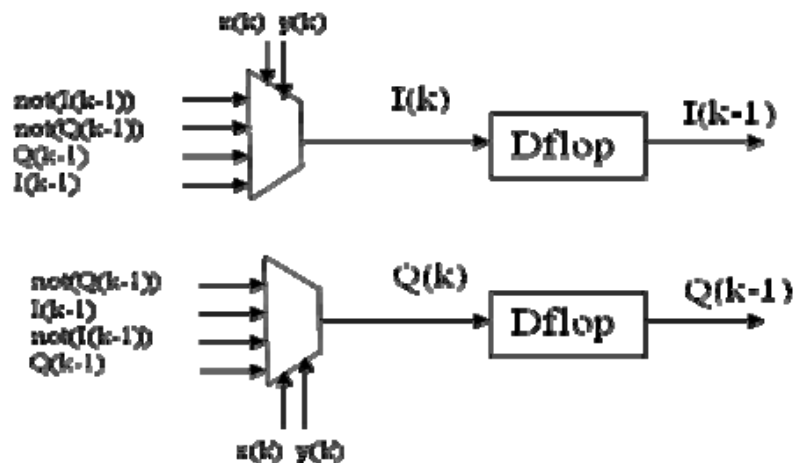

Fig 8: An implementation of the precoder

All of the three implementations shown above require feedback of the outputs within one symbol period (50 ps), which is difficult to achieve. Feed forward implementations are more amenable to implementation. Examples of feed forward implementations can be found in the literature (Ref. [5]).

2.5 DQPSK Receiver

A receiver can demodulate this DQPSK signal without the need for a local carrier. The received signal can be multiplied by a delayed version of itself (delayed by one symbol period) and filtered to obtain a signal which is a function of the phase difference –

$$x(t) * x(t - T)|_{lpf} = \cos(\theta(t) - \theta(t - T))$$

An optical receiver has the structure shown below

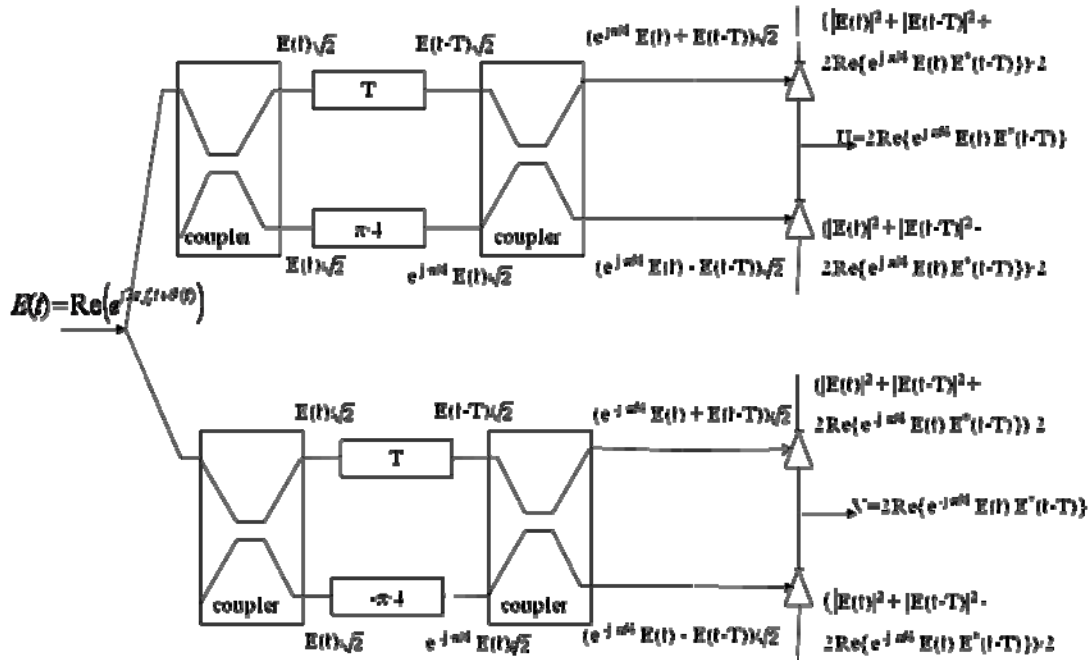

Fig 9: DQPSK optical demodulator with balanced photo detectors

E is the received electric field which is phase modulated. The optical coupler provides the sum and difference of the input signals at its two outputs. The outputs U and V are a function of the phase difference of the input signal E –

$$E(t) = e^{j\theta(k), (k-1)T \leq t < kT}$$

$$U = \text{Re}\{e^{j\pi/4} E(t) E^*(t-T)\} = \text{Re}\{e^{j\pi/4} e^{j\theta(k)} e^{-j\theta(k-1)}\} = \text{Re}\{e^{j\pi/4} e^{j(\theta(k) - \theta(k-1))}\}$$

$$= \cos(\pi/4 + \Delta\theta)$$

$$V = \text{Re}\{e^{-j\pi/4} E(t) E^*(t-T)\} = \text{Re}\{e^{-j\pi/4} e^{j\theta(k)} e^{-j\theta(k-1)}\} = \text{Re}\{e^{-j\pi/4} e^{j(\theta(k) - \theta(k-1))}\}$$

$$= \cos(-\pi/4 + \Delta\theta) = \cos(-\pi/2 + \pi/4 + \Delta\theta) = \sin(\pi/4 + \Delta\theta)$$

The values of U and V can then be used to estimate the transmitted symbol (X, Y) as follows

$\Delta\theta$	U	V	Logic(U)= X	Logic(V)= Y
0	$1/\sqrt{2}$	$1/\sqrt{2}$	1	1
$\pi/2$	$-1/\sqrt{2}$	$1/\sqrt{2}$	0	1
π	$-1/\sqrt{2}$	$-1/\sqrt{2}$	0	0
$3\pi/2$	$1/\sqrt{2}$	$-1/\sqrt{2}$	1	0

Table 4: Receiver mapping of phase change to bits

3 40G DQPSK EXPERIMENTAL SET-UP

In this section of the 40G DQPSK paper, we will demonstrate an error free 40 Gbps DQPSK optical link using the Sierra Monolithic SMI4025, a 40-45 Gbps 16:2 MUX/CMU with precoder, Inphi's optical modulator driver 2514DZ, a Dual Drive MZ optical modulator, a DQPSK demodulator, and balanced PD receiver.

3.1 40G DQPSK transmitter

Experimental set-up:

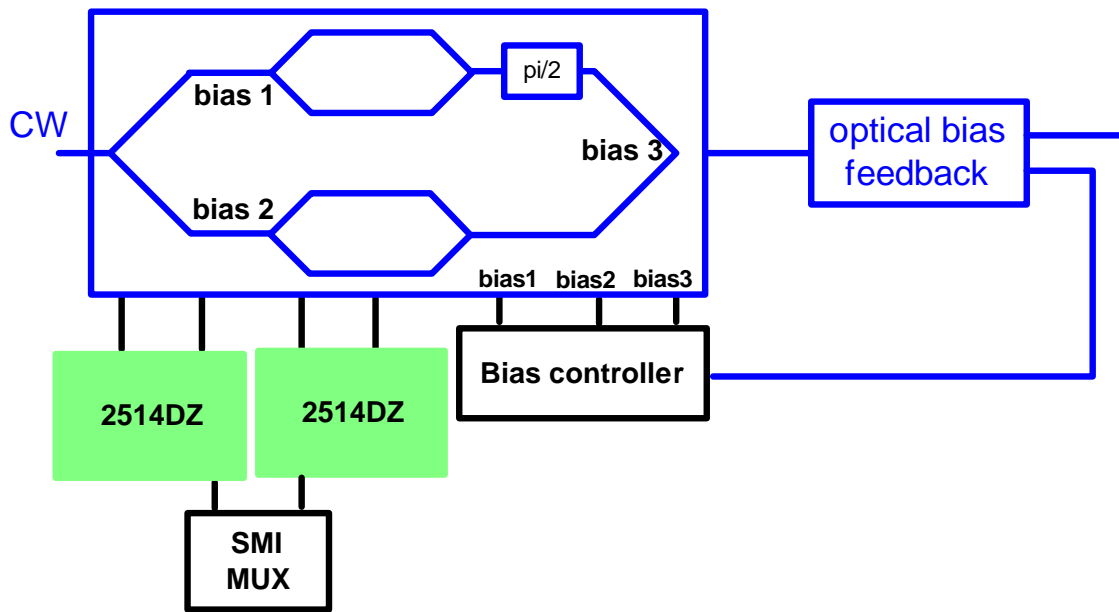

Fig 10: 40 Gbps DQPSK Optical Link Experimental set-up

The SMI4025 from SMI, a 40-45 Gbps 16:2 MUX/CMU with a user-enabled DQPSK precoder function, is used as the data source to deliver a 250 mVpp to 500 mVpp single ended DQPSK modulated signal to each of the two Inphi 2514DZ 25 Gbps differential MZ drivers. The 2514DZ has a differential output and is capable of driving a DQPSK Optical Modulator with $2V\pi$ voltage from 4 Vpp to 8 Vpp. The 2514DZ can run at data rates up to 25 Gbps with rise and fall times of 12 ps and low jitter.

In DQPSK format, 4 phases are used and each phase is assigned a unique pattern of 2 bits. A DQPSK modulator is a multifunctional modulator, which consists of two sub-MZ interferometers embedded in a main MZ interferometer. This nested MZ modulator can generate optical signals in various modulation formats. The DQPSK modulator can control the in-phase (I) and quadrature (Q) components of the output

lightwave in each sub-MZ interferometer. In the 40Gbps DQPSK modulation case, each sub-MZ modulator functions as a 20 Gbps symbol DPSK modulator; therefore it does not require high-performance electrical circuits or additional equipment for polarization in the optical transmission system. Each of the two nested MZ modulators has to work at a null bias mode [8], where the optical output intensity of each sub-MZ goes to a minimum. The main MZ interferometer has to be biased at the quad point for the orthogonal combination of the I and Q components (Figure 11).

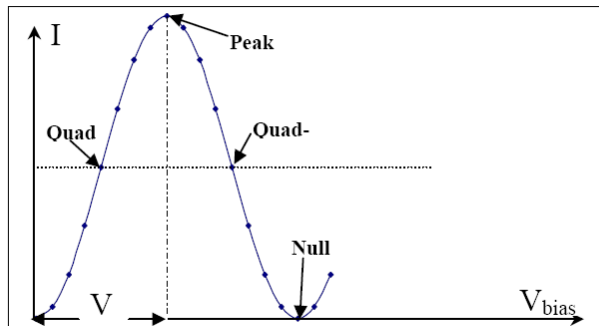

Fig 11: Optical output vs. Bias Voltage

The DC bias voltages of the three Mach Zehnders can be controlled manually or with an external bias control device. Since the operating bias points can drift with changing conditions, it is not recommended to control the modulator manually without compensation. However, if necessary, the following steps can be taken:

3.1.1 Manually controlled DC bias points:

With the CW laser on, and without applying any RF signal to the modulator, set the bias voltage of the first sub-MZ such that the average optical output power of the DQPSK modulator is at minimum. This is an indication that the sub-MZ is at the null position. Repeat this process with the second sub-MZ. Next, set the bias voltage of the main MZ such that the average optical output power is half way between the min and max powers. This is an indication that the main MZ is at the QUAD position. The benefit of the manual DC bias adjustment is that the set up is easy and straightforward. The shortcoming is that the operating bias points drift. Therefore, an external bias control device should be used that can compensate for the drift [9].

3.1.2 Automatic controlled DC bias point:

A commercially available modulator bias controller can be used that automatically sets the first and second modulators at the null point and the third at the quad. A feedback loop compensates for the change in operating conditions. In our set-up, we used a Dual-Parallel-MZ Modulator Bias Controller from YY Labs Inc. [8]. When this device is used, the RF driving signal should have amplitude of $2 V\pi$.

3.1.3 DQPSK modulator RF signal – Inphi’s 2514DZ modulator driver

An important parameter for any MZ modulator is $V\pi$, which is the voltage swing required to go from a null to a peak on the MZ transfer function curve. Thus, to generate DQPSK modulation, both I and Q arms of the modulator were push-pull driven by two modulator drivers with a differential output of $2V\pi$. One of the more common DQPSK modulators is the Z-cut modulator which requires a low voltage differential RF signal as its input. The typical modulator $V\pi$ in the market is 3.5 V. Differential drivers eliminate the chirp caused by a Z-cut MZ. Inphi’s 2514DZ is a differential output driver with swings up to 8 Vpp over temperature and power supply, which meets all DQPSK modulator operation requirements. The output of the 2514DZ has a GPPO interface to the modulator. The 500 mVpp DQPSK formatted signal was delivered to the 2514DZ input pin INp from the SMI4025 MUX/CMU.

Figure 12 shows the 500 mV output signal from the SMI4025 and Figure 13 shows the corresponding output signal from the 2514DZ modulator driver set to a 3.5 V output.

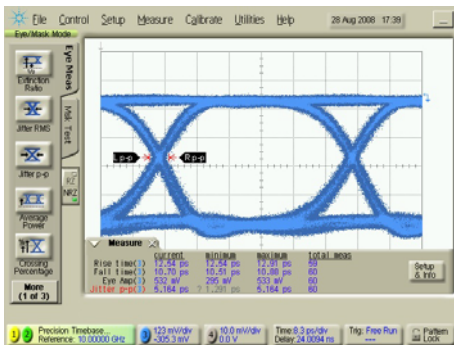

Fig 12: SMI4025 500mV output

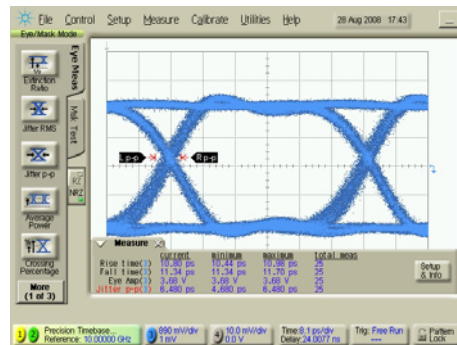

Fig 13: 2514DZ 3.5V output

The following Figure 14 shows the DPSK optical signal with only one 2514DZ modulator driver on.

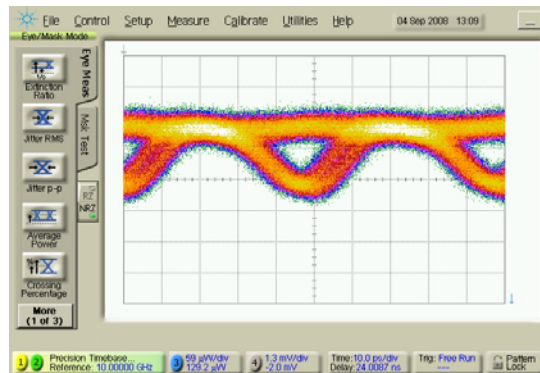

Fig 14: Optical DPSK signal

Figure 15 shows the DQPSK optical signal with the skew adjusted between the I and Q signals. When the output of the MZ modulator is viewed on a scope, amplitude changes are observed. This is because the amplitude also changes as the phase of the carrier changes. For example, when the input symbol is (0,0) the phase changes by 180 degrees and to do so, the envelope of the carrier momentarily goes to zero as the phase changes. This is clearly seen in the oscilloscope screen captured below of the MZ output.

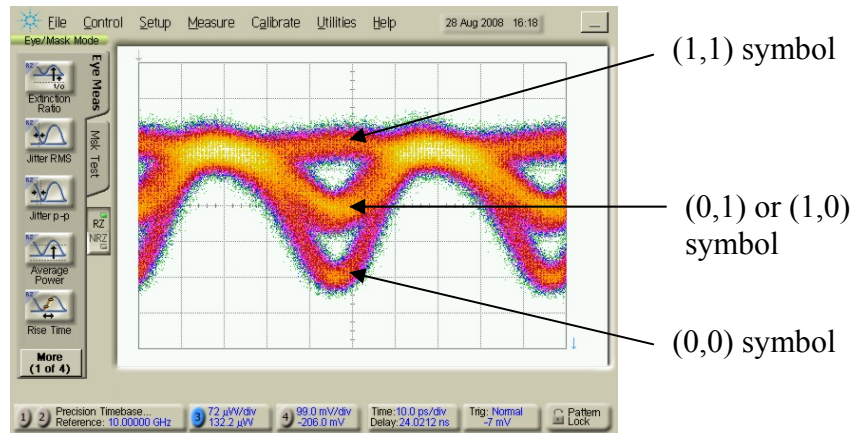

Fig 15: Output of MZ modulator

3.2 40G DQPSK Receiver

On the receiver side of the 40G DQPSK link, an optical demodulator and balanced receiver are used. As mentioned above, each of the 4 phases is assigned a unique pattern of binary bits by using a DQPSK modulator and precoder. The receiver needs to determine the phase of the received signal and map it back to the symbol it represents, thus recovering the original data.

3.2.1 40G Optical Demodulator

The 40G DQPSK optical demodulator combines two Mach Zehnder delay interferometers which are $\pi/4$ phase shifted from each other. Figure 16 shows only one optical demodulator [11]. The incoming optical signal is split at the input into two channels with a small delay before recombination. The beams from the two channels interfere constructively or destructively. The interference intensity is measured and becomes the intensity-keyed signal. To achieve this, one channel has an optical path longer than the other one by a distance equivalent to the photon flight time of one bit. For instance, at 20 Gbps, one bit is equal to 50 ps and light travels 15 mm on that period. In this example the optical path difference between the two channels is 15 mm. See Figure 16 for the schematic [12].

Schematic of the A-DI

- Based on a free-space optical Michelson interferometer.

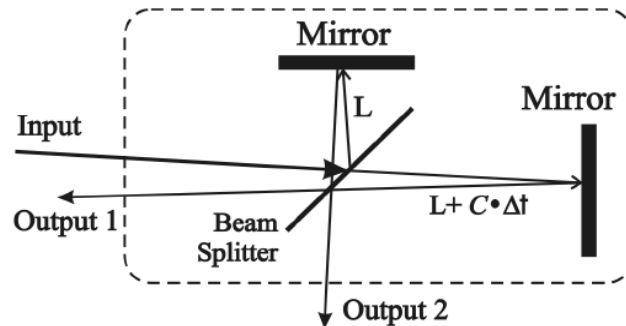

C is the speed of the light, L is the round-trip length of one path, and $\Delta t = 20\text{ps}$ is the round-trip time delay between the two paths of the DI.

Fig 16: Schematic of 1 bit Optical Demodulator

The commercially available optical DQPSK demodulator has four tuning bias voltages for I and I-, Q and Q-. By changing the tuning, the intensity of these 4 outputs can be adjusted independently. See the receiver test set up Figure 17.

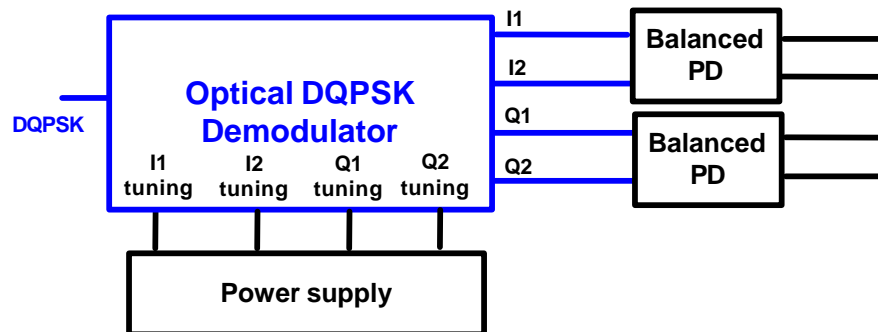

Fig 17: 40G DQPSK receiver test set up

The following plots are the outputs of I1, I2, Q1 and Q2.

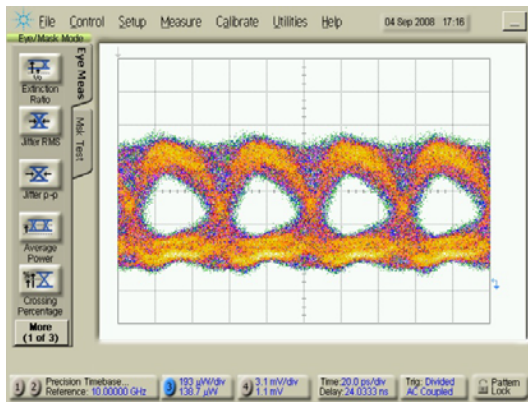

Fig 18: Demodulator output I1

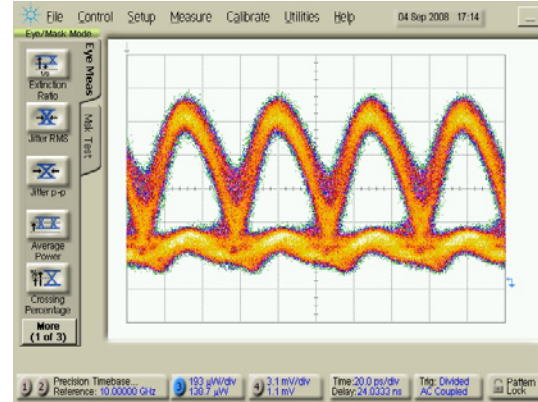

Fig 19: Demodulator output I2

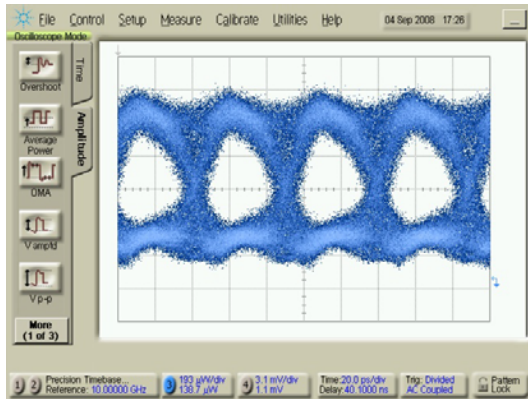

Fig 20: Demodulator output Q1

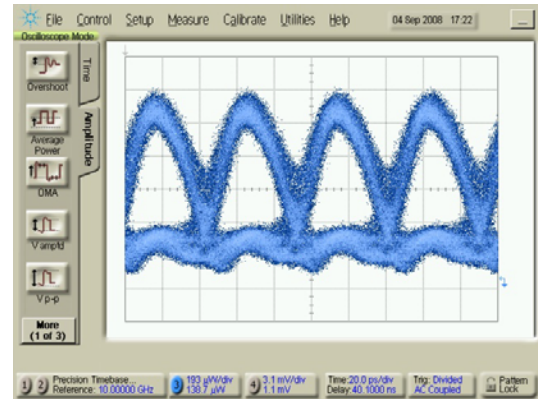

Fig 21: Demodulator output Q2

A balanced PD following the optical demodulator is used to combine differential optical inputs and provide an electrical output. Currently, there is no known differential TIA in the market, so available balanced receivers are a combination of balanced PD with a post amplifier. However, the post amplifier does not have the sensitivity that a TIA has. Figure 22 shows the electrical output from one of the balanced PDs. A post amplifier was not used in this configuration.

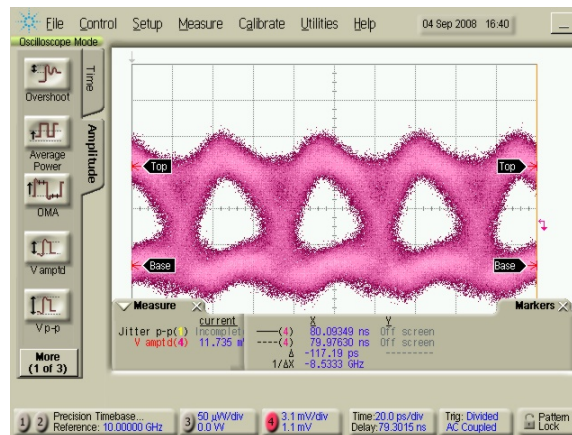

Fig 22: Electrical Output PD

3.2.2 40G DQPSK Experimental set-up

Figure 23 shows the experimental setup for a DQPSK system, including a transmitter and receiver.

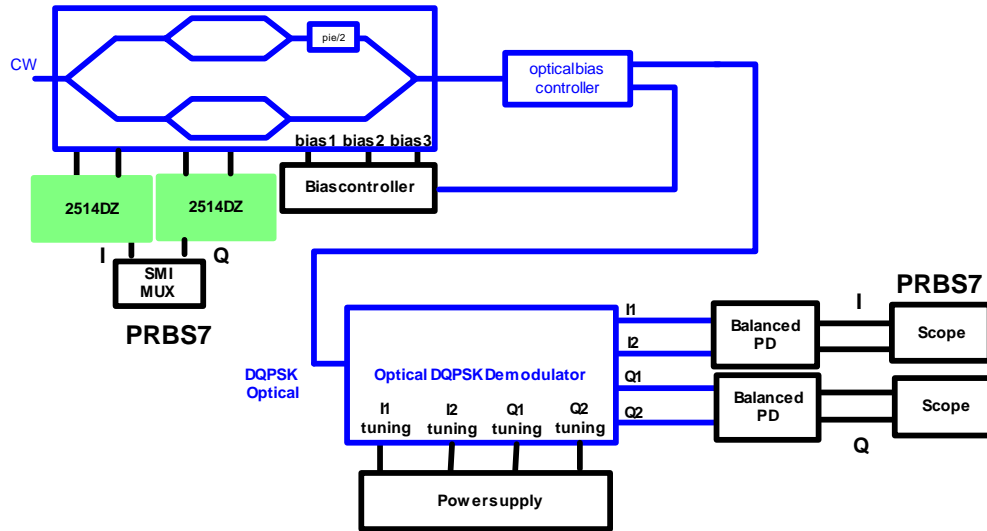

Fig 23: 40G DQPSK complete test set up

In order to verify error free links, a Bit Error Rate Tester (BERT) should be used. However, the limited amplitude at the output of the balanced PD (about 10 mV with -2 dBm optical power) did not allow us to test for errors using a BERT. As a result, instead of using a BERT, we transmitted a PRBS7 pattern and used the sampling scope to display the pattern. The displayed pattern matched a PRBS7 pattern. See Figure 24 for the receiver pattern output.

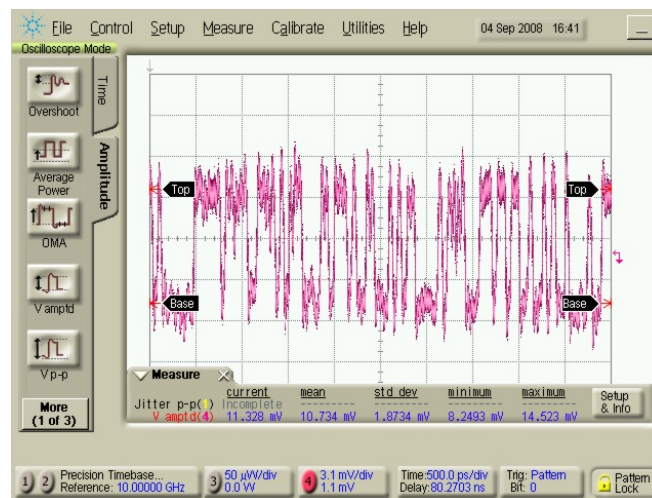

Fig 24: Receiver pattern output

4 CONCLUSIONS

Multi-level modulation techniques allow for systems to transmit higher bits rates in densely spaced wavelength division multiplexed (WDM) channels. 40G DQPSK and 100G DP-QPSK are attractive solutions for long haul transmission with better tolerance to impairments such as Chromatic Dispersion and PMD, and higher spectral efficiency. The increased availability of components in the market is making this complex DQPSK solution possible.

Reference:

1. J. G. Proakis, "Digital Communication Systems", McGraw Hill
2. A. H. Gnauck, P. J. Winzer, "Optical Phase Shift Keyed Transmission", J. of Lightwave Technology, Vol. 23, No. 1, Jan 2005
3. R. A. Griffin, A.C. Carter, "Optical Differential Quadrature Phase Shift Keying for High Capacity Optical Transmission", OFC 2002
4. K. Ho, "Phase Modulated Optical Communications Systems", Springer
5. M. Serbay, C. Wree, W. Rosenkranz, "Implementation of differential precoder for high speed optical transmission", Electronics Letters, Vol. 40, No. 20, 2004
6. Dr. Olga Vassilieva "40Gb/s & 100Gb/s Transport in the WAN" Fujitsu Laboratories of America, Inc. Richardson, Texas.
<http://members.internet2.edu/corporate/webinar/files/20070712-webinar-Vassilieva.pdf>
7. D.van den Borne, et.al, "DQPSK modulation for robust optical transmission" in proc OFC'08, paper OMQ1
8. Yin, Pub. No: US2007/0212075 A1, Pub. Date: Sep. 13, 2007, United States Patent Application Publication
9. Kaory Higuma, "A bias condition monitor technique for the nested Mach-Zehnder modulator", IEICE 2006
10. Masaharu Doi, "40Gb/s Low-drive-voltage LiNbO₃ Optical Modulator for DQPSK Modulation Format"
11. Jay (Y.C.) Hsieh, "A Thermal Demodulator for 42.7 Gb/s NRZ-DPSK Signal" ECOC'05 paper
12. Hsieh, Pub. No: US2007/0070505 A1, Pub. Date: Mar. 29, 2007, United States Patent Application Publication